



MAG-DRIVE ROTARY VANE PUMPS

SEAL-LESS MAG DRIVE VANE PUMPS

In seal-less magnetic drive vane pumps, the external magnet is directly connected to the motor shaft and it transmits the torque to the internal magnet. The magnetic field created produces a rotation without physical contact between the parts and the rotor spins. The vanes inside the rotor slide in and out of their seat and they move the fluid. The rear casing is placed between the two magnet joints and it hermetically closes the hydraulic part from the motor.

GemmeCotti supplies two different models of volumetric pumps:

HPP/HPF PP/PVDF

- Thermoplastic pumps made of PP or PVDF.
- Capacity up to 980 L/h.
- Pressure up to 5 bar.

HTP AISI 316

- Metallic pumps made of stainless steel AISI 316.
- Capacity up to 2100 L/h.
- Pressure up to 13 bar.
- Dry self-priming.

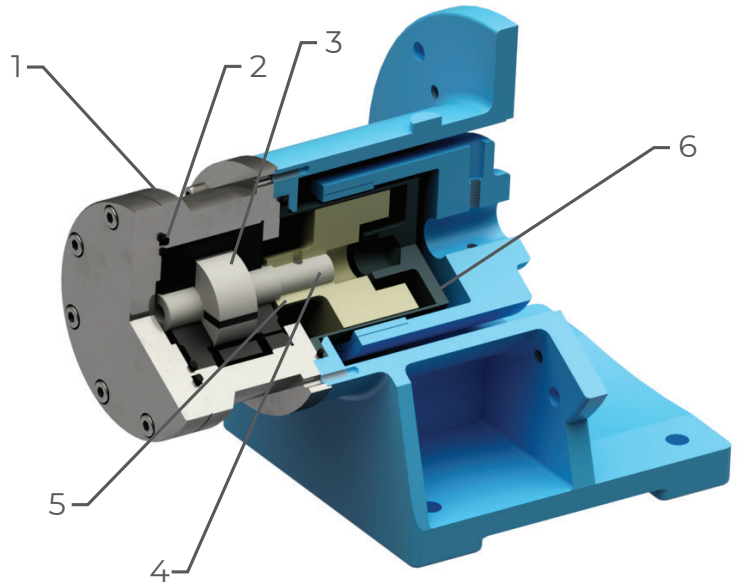

MATERIALS IN CONTACT WITH THE LIQUID		
PART NUMBER - DESCRIPTION	VANE PUMPS	
	HPP / HPF	HTP
1 - PUMP BODY + COVER	PP or PVDF	AISI 316
2 - O-RING	EPDM or VITON	EPDM or VITON
3 - FLANGES STATOR VANES + PINS	PVDF + GRAPHITE	GRAPHITE
4 - ROTOR SHAFT	PVDF	AISI 316
5 - INTERNAL MAGNET	PP or PVDF + NdFeB	AISI 316 + SmCo
6 - REAR CASING	PP or PVDF	AISI 316



THERMOPLASTIC MAG-DRIVE ROTARY VANE PUMPS



STANDARD

- High torque magnetic coupling.
- Direct starting motors.

OPTIONAL

- Flanges available (DIN or ANSI).
- Dry-running protection device.
- Baseplate.
- Available in ATEX version for zone 2 II 3G (pump mod. EM-P PP/PVDF).

Mag drive rotary vane pumps series **HPP-HPF** are made of thermoplastic materials (PP/PVDF) and are suitable for corrosive liquids, alkalis, toxic, noxious and carcinogenic fluids. Thanks to the **innovative mag drive system**, pumps model HPP-HPF reduce the risks of leakage and the maintenance costs. HPP-HPF pumps are **useful for low flow and high head applications** such as Pilot Plants and Sampling.

MAIN FEATURES

- **Materials available:** PP / PVDF.
- **Materials in contact with the liquid:** casing, end cover, internal magnet and rear casing: PP/PVDF; o-ring: EPDM (standard for PP pumps); VITON (standard for PVDF pumps); Graphite Stator; Rotor shaft: PVDF.
- **Max flow:** 980 L/h; **Max pressure** 5 bar.
- **Temperature:** PP: max 70°C - PVDF: max 90°C.
- **System pressure:** NP 5 bar at 20°C.

PERFORMANCE CURVES 50Hz - 1450 RPM

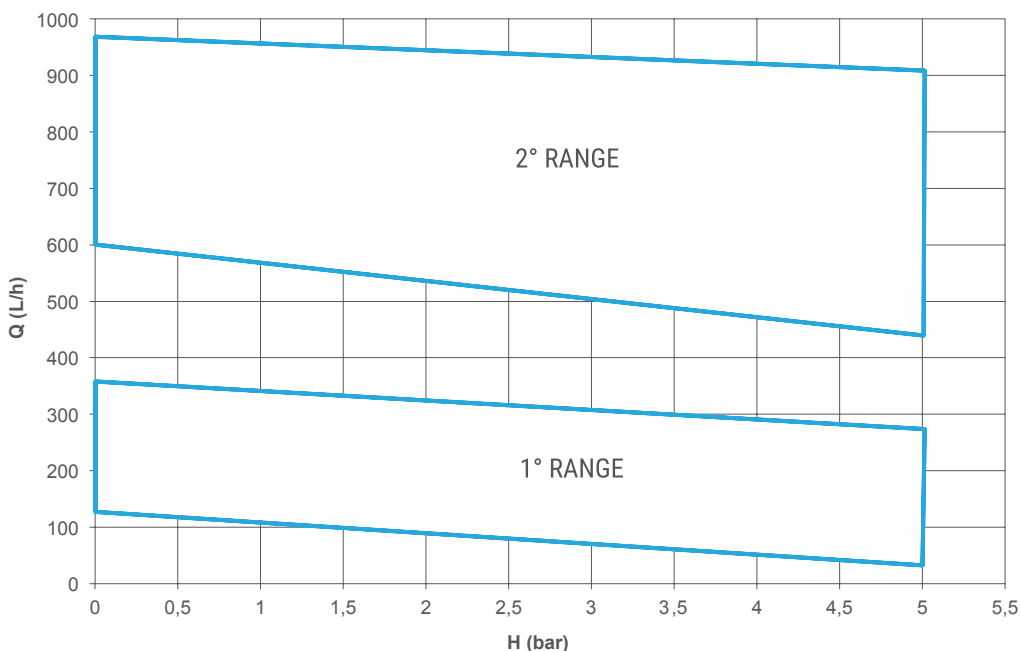

HPP/HPF TECHNICAL DATA

PUMP SIZE	MATERIAL	Q MAX		H MAX		SUCTION CONNECTION	DISCHARGE CONNECTION	PUMP WEIGHT (kg)		SUITABLE MOTOR POWER (kW) 1450 rpm	MOTOR FLANGE AND FRAME
		50Hz (L/h)	60Hz (USGPM)	50Hz (bar)	60Hz (PSI)			PP	PVDF		
HPP/HPF 100 1'R	PP- PVDF	120	0.66	5	72	3/8" FEMALE	3/8" FEMALE	2.9	3.2	0.37	71 - B3 / B5
HPP/HPF 200 1'R	PP- PVDF	200	1.1	5	72	3/8" FEMALE	3/8" FEMALE	2.9	3.2	0.37	71 - B3 / B5
HPP/HPF 300 1'R	PP- PVDF	290	1.5	5	72	3/8" FEMALE	3/8" FEMALE	2.9	3.2	0.37	71 - B3 / B5
HPP/HPF 400 1'R	PP- PVDF	360	1.8	5	72	3/8" FEMALE	3/8" FEMALE	2.9	3.2	0.37	71 - B3 / B5
HPP/HPF 600 2'R	PP- PVDF	600	2.5	5	72	1/2" FEMALE	1/2" FEMALE	7	7.5	1.5	90 - B3 / B5
HPP/HPF 800 2'R	PP- PVDF	800	3	5	72	1/2" FEMALE	1/2" FEMALE	7	7.5	1.5	90 - B3 / B5
HPP/HPF 1000 2'R	PP- PVDF	980	3.5	5	72	1/2" FEMALE	1/2" FEMALE	7	7.5	1.5	90 - B3 / B5

HPP-HPF 1° RANGE

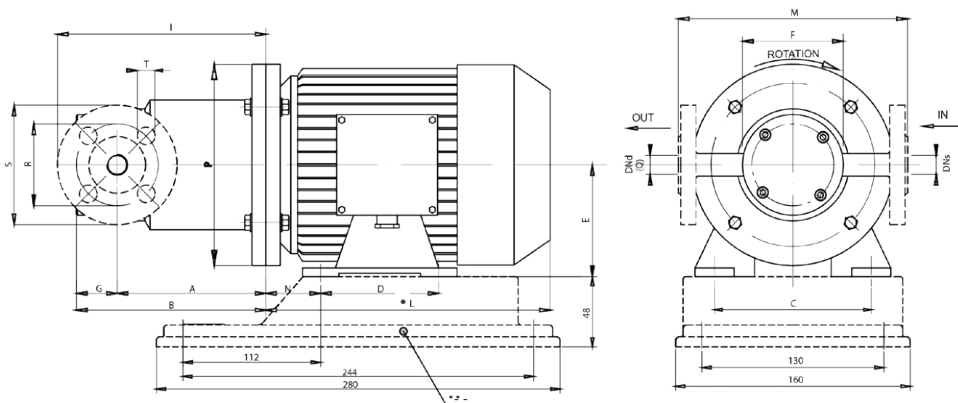

HPP-HPF 2° RANGE

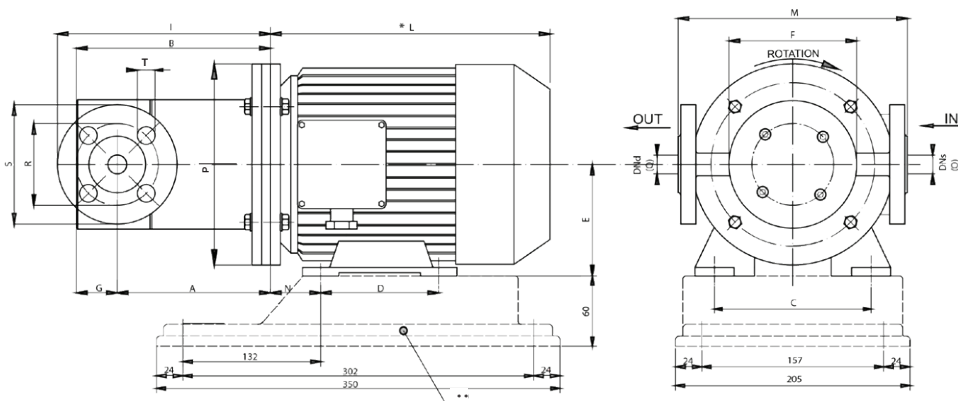

DIMENSIONS - mm -

PUMP TYPE	MOTOR FLANGE B3 - B5	kW	DIMENSIONS - mm -													FLANGES DIMENSIONS - mm -						
			A	B	C	D	E	F	G	I	*L	M	N	O	P	Q	R	S	T	DNs	DNd	
HPP-HPF1° RANGE	714B	0.37	128	164	112	90	71	90	36	176	215	182	45	3/8" FEMALE	160	3/8" FEMALE	65	95	14	15	15	DN15 PN16
HPP-HPF2° RANGE	90S2	1.1 1.5	179	223	140	100	90	127	44	232	255	218	56	1/2" FEMALE	200	1/2" FEMALE	75	105	14	20	20	DN20 PN16

* Different according to the manufacturer. ** OPTIONAL UPON REQUEST: DIN or ANSI Flanges and Baseplates.



HTP AISI 316

METALLIC MAG-DRIVE ROTARY VANE PUMPS DRY SELF-PRIMING



Rotary vane mag drive pumps series **HTP** are made of **AISI 316** and are suitable for hydrocarbons, solvents, heat transfer oils, refrigerants, cryogenics and radioactive liquids. Thanks to the **innovative mag drive system**, pumps model HTP reduce the risks of leakage and emissions and the maintenance costs. HTP pumps are **useful for low flow and high head applications** such as Pilot Plants, Sampling and Flushing of mechanical seals. Especially designed for thin non-lubricating liquids and/or high differential pressure. Pumps series HTP are also available in **ATEX version for zone 1 and 2** (pump model EM-P AISI 316).

STANDARD

- High torque magnetic coupling.
- Direct starting motor.

OPTIONAL

- Flanges available (DIN or ANSI).
- Dry-running protection device.
- Baseplate.
- Explosion proof motor.
- Available in ATEX version for zone 1 II2G and zone 2 II 3G (pump mod. EM-P AISI 316).

MAIN FEATURES

- **Materials available:** AISI 316.
- **Materials in contact with the liquid:** pump body, end cover and rotor: AISI 316; o-ring: EPDM/VITON; carbon graphite stator.
- **Max flow:** 2100 L/h; **Max head** 13 bar.
- **Temperature range:** from - 70°C to + 200°C
- **Max viscosity:** 2000 cPs.
- **System pressure:** 25 bar at 20°C.
- Standard motor 4 poles

PERFORMANCE CURVES 50Hz - 1450 RPM

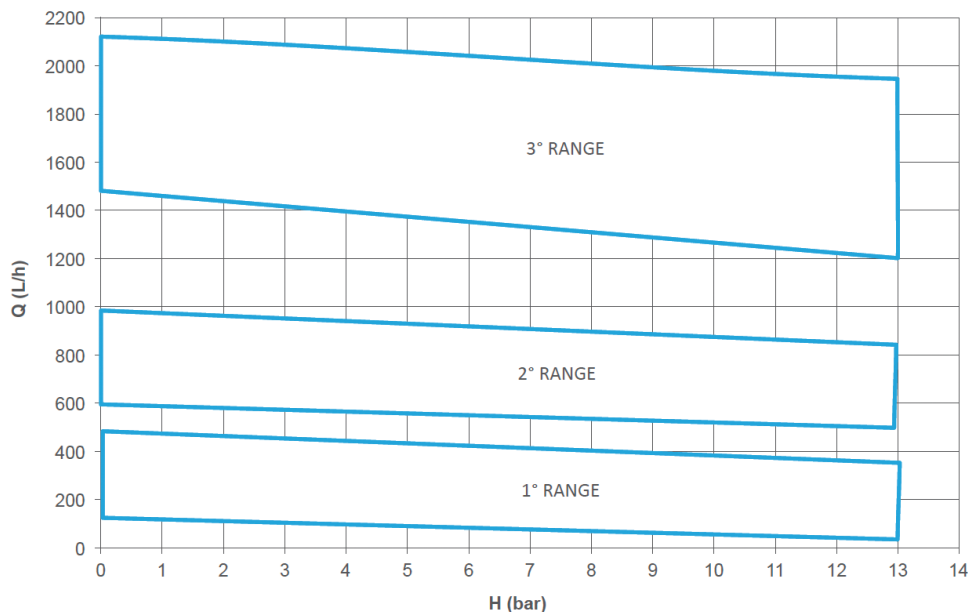

HTP TECHNICAL DATA

PUMP SIZE	MATERIAL	Q MAX		H MAX		SUCTION CONNECTION	DISCHARGE CONNECTION	PUMP WEIGHT (kg)	SUITABLE MOTOR POWER (kW) 1450 rpm - 4 POLES	MOTOR FLANGE AND FRAME
		50Hz (L/h)	60Hz (USGPM)	50Hz (bar)	60Hz (PSI)					
HTP 100 1R	AISI 316	120	0.66	13	188	3/8" FEMALE	3/8" FEMALE	3.4	0.37	71 - B3 / B5
HTP 200 1R	AISI 316	250	1.4	13	188	3/8" FEMALE	3/8" FEMALE	3.4	0.37	71 - B3 / B5
HTP 300 1R	AISI 316	350	1.9	13	188	3/8" FEMALE	3/8" FEMALE	3.4	0.37	71 - B3 / B5
HTP 400 1R	AISI 316	450	2.3	13	188	3/8" FEMALE	3/8" FEMALE	3.4	0.37	71 - B3 / B5
HTP 600 2R	AISI 316	600	3.3	13	188	1/2" FEMALE	1/2" FEMALE	8.1	0.75	80 - B3 / B5
HTP 800 2R	AISI 316	800	4.3	13	188	1/2" FEMALE	1/2" FEMALE	8.1	0.75	80 - B3 / B5
HTP 1000 2R	AISI 316	980	5	13	188	1/2" FEMALE	1/2" FEMALE	8.1	1.5	90 - B3 / B5
HTP 1500 3R	AISI 316	1500	8	13	188	3/4" FEMALE	3/4" FEMALE	22.6	1.5	90 - B5
HTP 2000 3R	AISI 316	2100	11.1	13	188	3/4" FEMALE	3/4" FEMALE	22.6	2.2 3 4	100 - B5 100 - B5 112 - B5

HTP 1°-2° RANGE / EM-P 1° - 2° RANGE (ATEX VERSION)

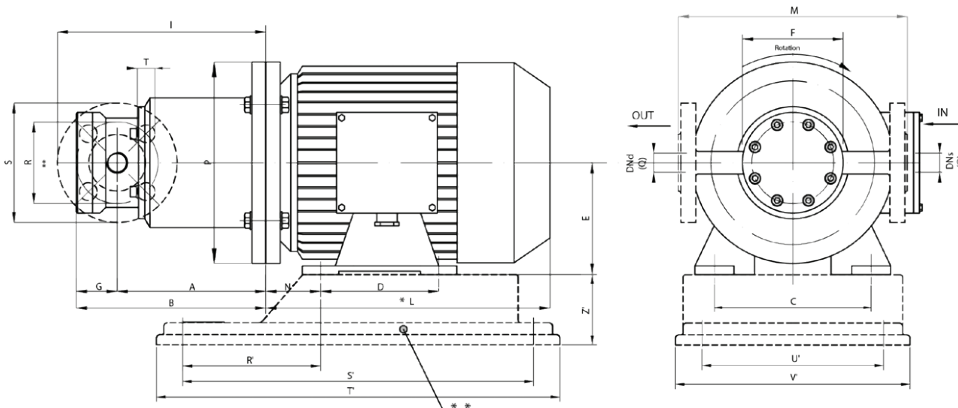

DIMENSIONS - mm -

PUMP TYPE	MOTOR FLANGES B3-B5		DIMENSIONS - mm -														BASEPLATE DIMENSIONS - mm -					
	SIZE	KW	A	B	C	D	E	F	G	I	*L	M	N	O	P	Q	R'	S'	T'	U'	V'	Z'
HTP 1° RANGE	714B	0.37	127	160	112	90	71	80	33	175	215	182	45	3/8" FEMALE	160	3/8" FEMALE	112	244	280	130	160	48
HTP 2° RANGE	804B 90L4	0.75 1.5	166 176	204 214	125 140	100 125	80 90	123	38	218	232 280	194	50 56	1/2" FEMALE	200	1/2" FEMALE	120 132	302	350	157	205	60

FLANGES DIMENSIONS - mm -

PUMP TYPE	R	S	T	DNs	DNd	
HTP 1° RANGE	65	95	14	15	15	DN15 PN40
HTP 2° RANGE	75	105	14	20	20	DN20 PN40

* Different according to the motor supplier.
 ** OPTIONAL UPON REQUEST: DIN or ANSI Flanges and Baseplates.
 NOTE: DIRECTION OF ROTATION IS COUNTER CLOCKWISE AS SEEN WHEN FACING THE MOTOR. PUMPS AVAILABLE THREADED OR FLANGED.



HTP AISI 316

METALLIC MAG-DRIVE ROTARY VANE PUMPS DRY SELF-PRIMING



HTP 3° RANGE / EM-P 3° RANGE (ATEX VERSION)

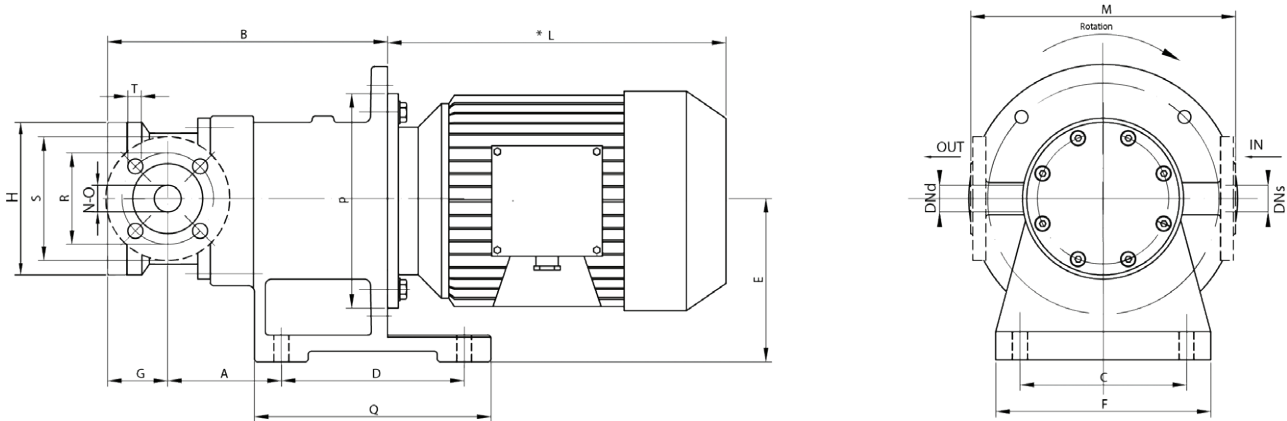

DIMENSIONS - mm -

PUMP TYPE	MOTOR FLANGE B5		DIMENSIONS - mm -													
	SIZE	kW	A	B	C	D	E	F	G	H	*L	M	N	O	P	Q
HTP 3° RANGE	90L	1.5	106	260	155	170	150	200	56	142	280	246	3/4" FEMALE	3/4" FEMALE	200	220
	100L	2.2/3	106	280	155	170	150	200	56	142	316	246	3/4" FEMALE	3/4" FEMALE	250	220
	112M	4	106	280	155	170	150	200	56	142	334	246	3/4" FEMALE	3/4" FEMALE	250	220

* Different according to the motor supplier. ** OPTIONAL UPON REQUEST: DIN or ANSI Flanges.
NOTE: DIRECTION OF ROTATION IS COUNTER CLOCKWISE AS SEEN WHEN FACING THE MOTOR.
PUMPS AVAILABLE THREADED OR FLANGED.

FLANGES DIMENSIONS - mm -

PUMP TYPE	R	S	T	DNs	DNd	
HTP 3° RANGE	85	115	14	25	25	DN25 PN40